

CLAMPBO®

WOODWORKER



40" COPY FUNCTION WOODLATHE

MODEL NO: CWL1000CF

PART NO: 6500689

OPERATION & MAINTENANCE INSTRUCTIONS

UK
CA | CE



ORIGINAL INSTRUCTIONS

DL0123 - ISS 4

INTRODUCTION

Thank you for purchasing this CLARKE Woodlathe.

Before attempting to operate the lathe it is essential that you read this manual thoroughly and carefully follow all instructions given.

In doing so you will ensure the safety of yourself and that of others around you, and you can also look forward to the product giving you long and satisfactory service.

Please keep these instructions for future reference.

SPECIFICATIONS

Weight	60.5 kg
Dimensions (L x W x H)	1415 x 455 x 1180 mm
Stand footprint	1380 x 430 mm
Speed	600-2200 rpm variable
Distance between centres	980 mm
Height of centreline from base frame	173mm
Turning Capacity	350 mm
Headstock Thread	3/4" x 16TPI (UNF)
Headstock taper	MT1
Tailstock taper	MT2
Tool rest length	300 mm
Face plate diameter	150 mm
Motor voltage/frequency	230V / 50Hz
Rated input wattage	550 W
Sound Pressure Level (Lp)	No load 73.9 / loaded 78.4 dB(A)
Sound Power Level Measured (Lw)	No load 82.8 / loaded 89.8 dB(A)
Uncertainty K	3 dB(A)

SAFETY WARNINGS



WARNING: FAILURE TO FOLLOW THESE PRECAUTIONS COULD RESULT IN PERSONAL INJURY, AND/OR DAMAGE TO PROPERTY.

WORK ENVIRONMENT

1. **Keep the work area clean and well lit.** Cluttered and dark areas invite accidents.
2. **Do not operate power tools in explosive atmospheres, such as in the presence of flammable liquids, gases or dust.** Power tools create sparks which may ignite the dust or fumes.
3. **Keep children and bystanders away while operating a power tool. Anyone entering the work area must wear personal protective equipment.** Distractions can cause you to lose control and fragments of work may fly away and cause injury.
4. **Store power tools properly when not in use.** Abrasive products should be stored in a dry, secure place out of the reach of children.
5. Please read these instructions carefully and retain for future reference.

ELECTRICAL SAFETY

1. **Power tool plugs must match the outlet. Never modify the plug in any way. Do not use adaptor plugs with earthed (grounded) power tools.** Unmodified plugs and matching outlets will reduce the risk of electric shock.
2. **Do not expose power tools to rain or wet conditions.** Water entering a power tool will increase the risk of electric shock.
3. **Do not abuse the power cable. Never use the cable for carrying, pulling or unplugging the power tool. Keep the cable away from heat, oil, sharp edges or moving parts.** Damaged or entangled cables increase the risk of electric shock.

PERSONAL SAFETY

1. **Stay alert, watch what you are doing and use common sense when operating a power tool.** Do not use a power tool while you are tired or under the influence of drugs, alcohol or medication. A moment of inattention while operating power tools may result in personal injury.

2. **Use personal protective equipment.** Always wear eye protection. Safety equipment such as dust mask, non-skid safety shoes, hearing protection and a workshop apron capable of stopping small abrasive or workpiece fragments.
3. **Avoid accidental starting.** Ensure the switch is in the off position before plugging in. Plugging in power tools that have the switch on, invites accidents.
4. **Remove any adjusting key or wrench before turning the power tool on.** A wrench or a key left attached to a rotating part of the power tool may result in personal injury.
5. **Do not overreach.** Keep proper footing and balance at all times. This enables better control of the power tool in unexpected situations. Dress properly. Do not wear loose clothing or jewellery.
6. **Keep your hair, clothing and gloves away from moving parts.** Loose clothes, jewellery or long hair can be caught in moving parts. Keep the work area clean and tidy.
7. **Regularly clean the air vents.** The motor fan will draw dust inside the housing and accumulation of material could cause electrical hazards.
8. **Avoid operator fatigue.** Stop the lathe at regular intervals for a short break to rest hands and arms.
9. **Maintain your tools.** Keep all handles dry and clean. Keep chisels sharp.

ELECTRICAL SAFETY

1. Position the power cable so that it cannot be inadvertently pulled or pinched and where it does not cause a trip hazard.
2. This lathe is designed for indoor environments and must not be used for other purposes.
3. If the lathe requires repair, always contact your Clarke dealer. Always insist on original spare parts. Repairs carried out by unauthorized persons may be dangerous and invalidate the guarantee.
4. This lathe must only be used by adults. Children should not be allowed to play with the lathe.
5. Do not use extension power cables.
6. Before cleaning or maintenance operations, always unplug the lathe from the power supply.

POWER TOOL USE AND CARE

1. **Do not force the machine.** Use the correct tool for your task. It will do a better and safer job at the rate for which it was designed.

2. **Do not use the power tool if the switch does not turn it on and off.** Any power tool that cannot be controlled with the switch is dangerous and must be repaired.
3. **Disconnect the power tool from the power supply before making any adjustments, changing accessories, or storing the tool.** These measures will reduce the risk of the power tool starting accidentally.
4. **Store power tools out of the reach of children and do not allow persons unfamiliar with these instructions to operate the power tool.** Power tools are potentially dangerous in the hands of untrained users.
5. **Maintain tools in top condition.** Keep tools/ machines clean for the best and safest performance. Check for misalignment or binding of moving parts, broken parts, or any condition that may affect the power tool's operation. If damaged, have the power tool repaired before use. Many accidents are caused by poorly maintained power tools.
6. **Use recommended accessories.** The use of improper accessories could be hazardous.
7. **Machine cleanliness.** Do not allow the ventilation slots in the machine to become blocked with dust.
8. **Check the power tool for damage before using the machine.** Any damaged part should be inspected to ensure that it will operate properly and perform its intended function. Check for alignment of moving parts, breakage of parts, mountings, and any other condition that may affect the machine's operation. Any damage should be properly repaired or the part replaced. If in doubt, DO NOT use the machine. Consult your local dealer.

SERVICING

1. **When necessary, have your power tools serviced or repaired by a qualified person using identical replacement parts.** This will ensure that the safety of the power tool is maintained.

ADDITIONAL PRECAUTIONS FOR WOODLATHES



WARNING: DUST GENERATED FROM CERTAIN MATERIALS CAN BE HAZARDOUS TO YOUR HEALTH. ALWAYS OPERATE THE LATHE IN A WELL VENTILATED AREA. USE A DUST COLLECTION SYSTEM WHENEVER POSSIBLE.

1. Familiarise yourself with woodlathes and turning techniques before using the lathe. If in doubt you should consult an expert.
2. ALWAYS store chisels safely when you have finished work.
3. CAUTION: This lathe is designed for use with woodturning chisels only.
4. NEVER attempt to turn a workpiece unless a suitable support is used.

5. ALWAYS stop the lathe before removing workpieces, work supports or swarf from the table.
6. ALWAYS be sure that the workpiece is securely locked in position
7. ALWAYS keep hands and fingers away from the moving workpiece.

SAFETY SYMBOLS

The following safety symbols may be found on the machine.



Wear a dust mask



Wear eye protection



Read instruction manual before use

ENVIRONMENTAL PROTECTION

Recycle unwanted materials instead of disposing of them as waste. All unwanted accessories and packaging should be sorted and taken to a recycling centre for disposal in a manner which is compatible with the environment.

ENVIRONMENTAL RECYCLING POLICY



Through purchase of this product, the customer is taking on the obligation to deal with the WEEE in accordance with the WEEE regulations in relation to the treatment, recycling & recovery and environmentally sound disposal of the WEEE.

In effect, this means that this product must not be disposed of with general household waste but according to the laws governing Waste Electrical and Electronic Equipment (WEEE) at a recognised disposal facility.

ELECTRICAL CONNECTIONS



WARNING: READ THESE ELECTRICAL SAFETY INSTRUCTIONS THOROUGHLY BEFORE CONNECTING THE PRODUCT TO THE MAINS SUPPLY.

Before switching the product on, make sure that the voltage of your electricity supply is the same as that indicated on the rating plate. This product is designed to operate on 230VAC 50Hz. Connecting it to any other power source may cause damage.

This product may be fitted with a non-rewireable plug. If it is necessary to change the fuse in the plug, the fuse cover must be refitted. If the fuse cover becomes lost or damaged, the plug must not be used until a suitable replacement is obtained.

If the plug has to be changed because it is not suitable for your socket, or due to damage, it should be cut off and a replacement fitted, following the wiring instructions shown below. The old plug must be disposed of safely, as insertion into a mains socket could cause an electrical hazard.



**WARNING: THE WIRES IN THE POWER CABLE OF THIS PRODUCT ARE COLOURED IN ACCORDANCE WITH THE FOLLOWING CODE:
BLUE = NEUTRAL BROWN = LIVE YELLOW AND GREEN = EARTH**

If the colours of the wires in the power cable of this product do not correspond with the markings on the terminals of your plug, proceed as follows.

- The wire which is coloured **Blue** must be connected to the terminal which is marked **N** or coloured **Black**.
- The wire which is coloured **Brown** must be connected to the terminal which is marked **L** or coloured **Red**.
- The wire which is coloured **Yellow and Green** must be connected to the terminal which is marked **E** or  or coloured **Green**.

Plug must be BS1363/A approved.

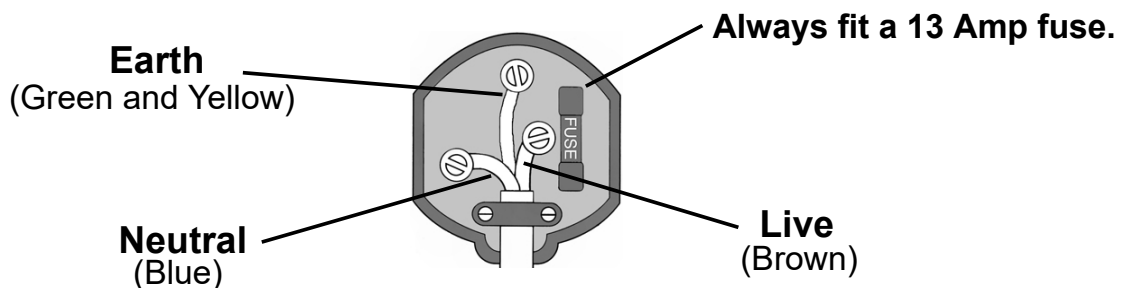

Ensure that the outer sheath of the cable is firmly held by the clamp

We strongly recommend that this machine is connected to the mains supply via a Residual Current Device (RCD)

If in any doubt, consult a qualified electrician.

MAIN COMPONENTS

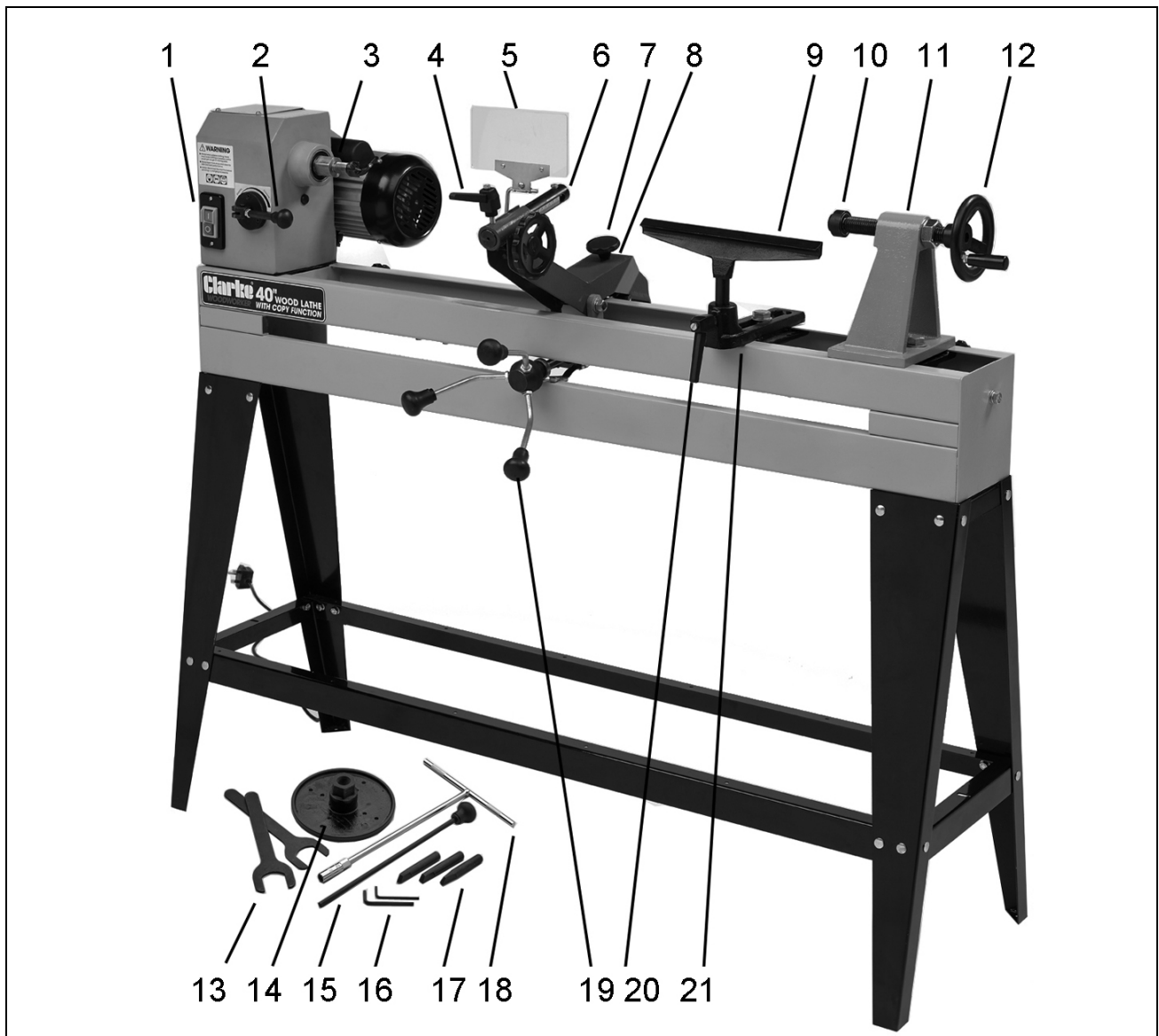

1	On/Off Switch
2	Speed control lever
3	Headstock centre spur
4	Copy tool locking lever
5	Face/Eyeshield
6	Copy tool holder
7	Copy tension adjuster
8	Copy follower
9	Tool rest
10	Tail stock spur assembly
11	Tailstock body

12	Tailstock advance handle
13	Open wrench
14	Faceplate
15	Drift rod
16	Hex keys
17	Cutting tool(s)
18	T-spanner
19	Leadscrew handle
20	Toolrest support locking handle
21	Toolrest support

UNPACKING & ASSEMBLY

When unpacking, check for damage or omissions etc. Any found should be reported to your CLARKE dealer where the lathe was originally purchased. Do not discard the packaging until the lathe is assembled.



WARNING: DUE TO THE WEIGHT OF THE LATHE BED ASSEMBLY IT IS ESSENTIAL THAT TWO PEOPLE PERFORM THE UNPACKING, ASSEMBLY AND POSITIONING.

The numbers in the following assembly instructions refer to the parts lists and diagrams on pages 18-22.

The following items are supplied loose:

1 x Tool Rest	2 x 32mm Open Wrench
1 x Tool Rest Holder fitted?	1 x 10mm T-Wrench
1 x Face Plate	1 x Fixings Pack
1 x Headstock Centre Spur	1 x Drift Rod
1 x Tailstock Spur	3 x Cutting Tools
1 x Copy Follower Assembly	4 x Stand Legs
1 x Tool Holder Locking Handle (fitted)	2 x Stand Long Support
3 x Leadscrew Handles	2 x Stand Short Supports
1 x Face shield	2 x Stand Top Plates
2 x Hex Keys (S3 & S4)	

ASSEMBLY OF THE STAND

1. Assemble the front & rear legs, supports and top plates using the coachbolts, nuts and washers as shown in Fig 1.
2. Assemble the stand loosely before tightening all the fixings together.
3. With the help of an assistant, position the lathe over the top plates and align the holes in the lathe bed with the holes in the stand top plate. Secure with the bolts supplied and tighten them evenly.



ASSEMBLY OF FACEPLATE, TAILSTOCK & LEADSCREW

1. If faceplate turning is required, screw the faceplate (24) onto the headstock spindle (42) while using the open wrench provided to prevent the spindle from turning. Tighten the faceplate as shown in Fig 2.
2. If spur turning is required, insert the headstock spur (25) into the tapered hole in the headstock spindle as shown in Fig 3a.

The spur can later easily be removed by driving it away from the headstock using the drift rod provided.

3. Insert the tail-stock spindle assembly (43/44/45) into the tail-stock as shown in Fig 3b, the taper of the shaft gripping it in place.

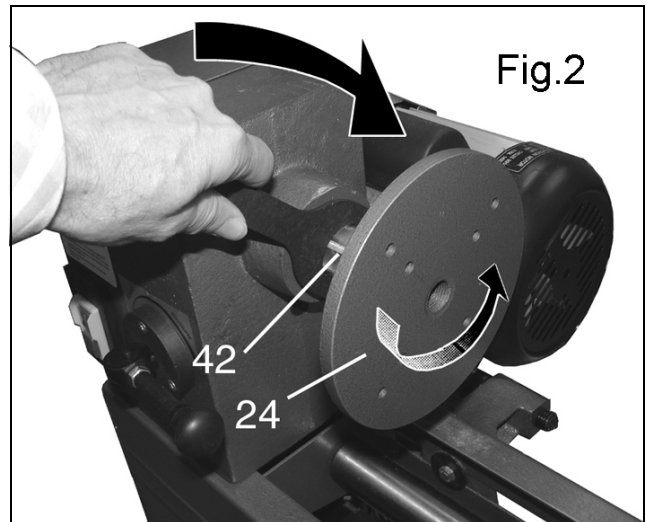

Fig.2

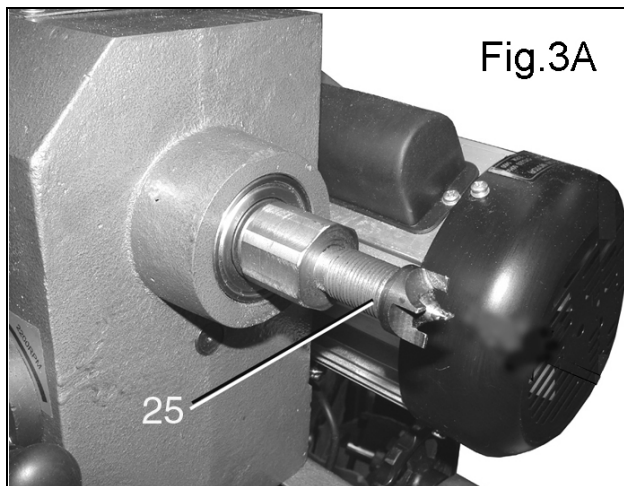

Fig.3A

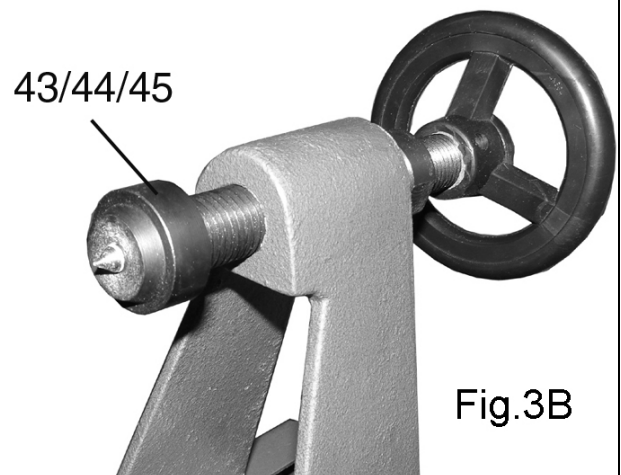

Fig.3B

4. Fit the leadscrew hub (79) onto the leadscrew axle (78) and secure with a grub-screw (50).
5. Screw the three leadscrew handles (113) into the leadscrew hub (79).
6. Ensure that the angle of each handle keeps it clear of the toolrest assembly and that each one is at right angles to the spindle to achieve equal spacing before securing in position with the locknuts.

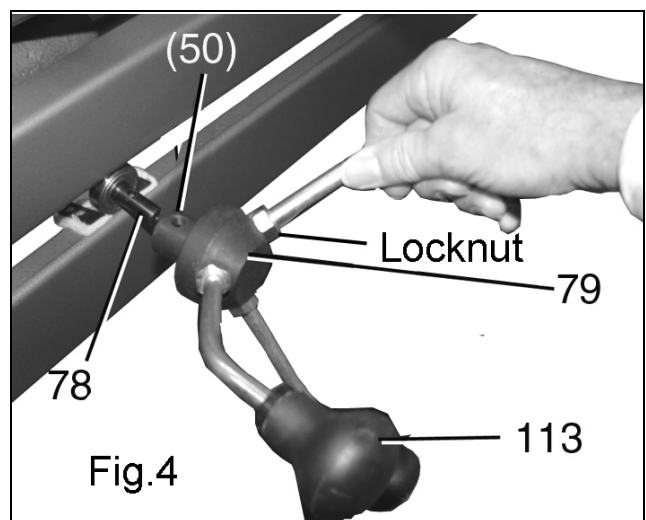
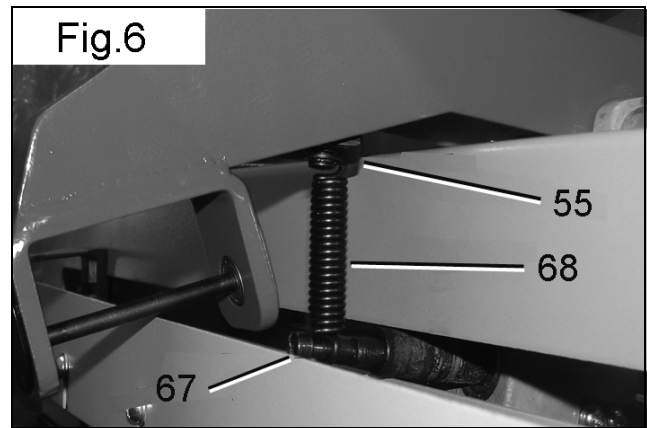
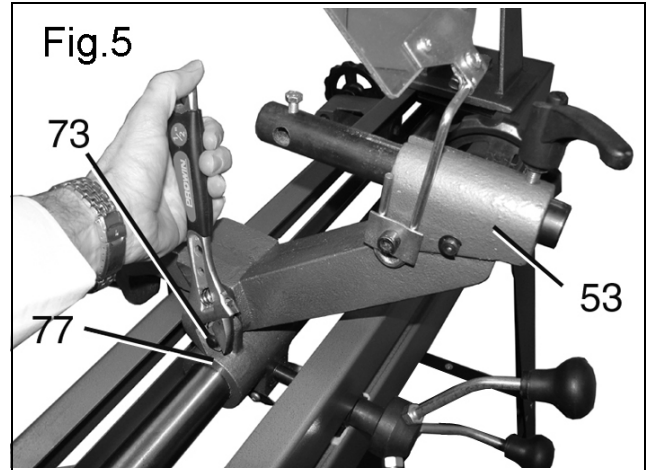

Fig.4

ASSEMBLY OF THE COPY FOLLOWER

If the copy system is to be used proceed as follows;

1. Position the copy follower body (53) over the lead screw 3-way trunnion (77) and connect it using the copy pivot stud bolt (73) and tighten the nuts on each side as shown in Fig 5.
2. Connect the copy tension spring (68) to the locating hole in the spring attachment plate (55).
3. Pass the slot-headed bolt (67) through the other end of the spring before screwing it into the tip of the leadscrew axle (78) as shown in Fig 6.



ASSEMBLING THE COPY TOOL

1. Install the copy tool holder rack (64) into the hole in the copy follower body (53) and drive it through using the handwheel (1) and the pinion gear (71) inside the copy follower body.
2. Insert your chosen cutting tool into the tool holder and tighten the retaining bolt (110) using the T-wrench as shown in Fig 7.
3. Advance the tool to the workpiece and secure with the locking handle (59). The tool tip should be at the same height as the centre axis of the lathe.

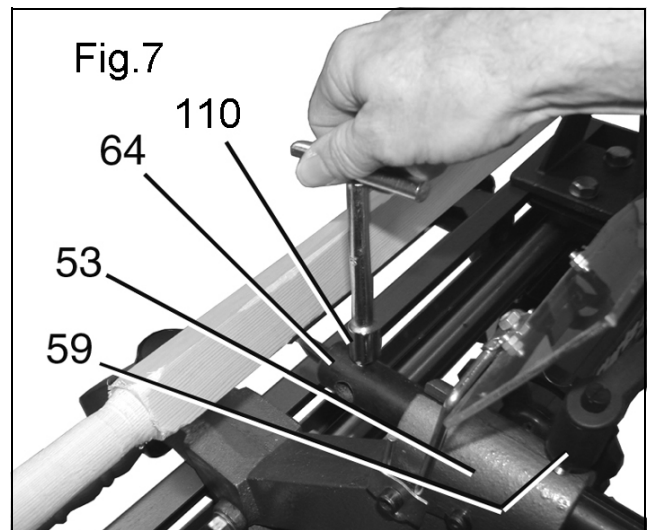

4. Fit the eyeshield (115) to the copy follower body using the socket-headed bolt (37) as shown in Fig 8.

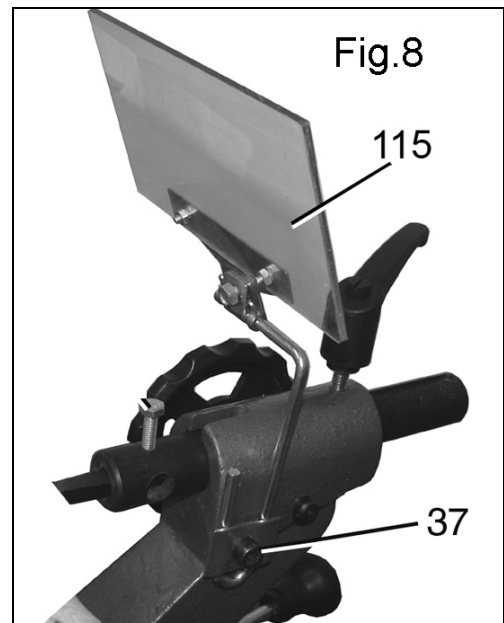

ASSEMBLING THE HAND CHISEL REST

If the copy system is not being used, the standard tool rest for hand chisels can be used as follows:

1. Set the chisel rest holder (101) on the lathe bed and secure in position with the securing plate (108) and the bolt/washer (94/95) as shown in Fig 9.
2. Position the working edge of the rest (100) level with the centre axis of the lathe and secure with the locking lever.
3. Position the rest level slightly above the lathe centreline and approx 3mm from the workpiece and tighten the locking handle (59) to secure. The rest can be used parallel with the workpiece or at 90 degrees for faceplate turning.

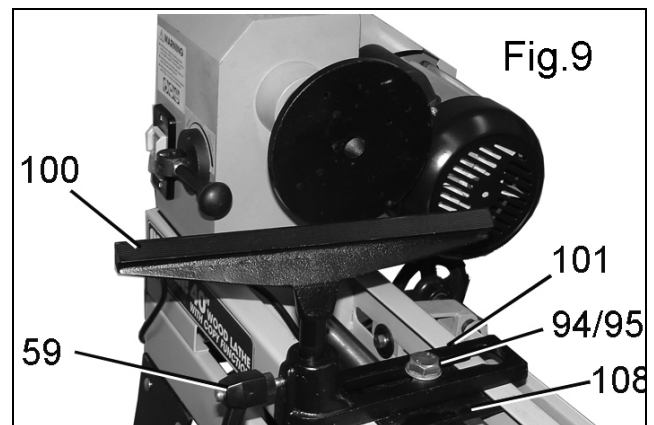

OPERATION

1. Ensure the cutting tool, tool rests and tailstock are securely locked in position before starting work.
2. Always rotate the workpiece by hand and check it does not strike the tool/ tool rest before switching on the motor.
3. To turn the lathe ON, press the green push-button. Press the red button to stop.

4. Avoid turning timber which has splits or substantial knots or voids and take special care if these are discovered.
5. Always use the lowest speed when starting a new workpiece.
6. When turning, always roughly turn the work to a cylinder at low speed.
7. Take care that the turning tools do not bite suddenly into the workpiece.
8. Always position the tool-rest just above the centreline of the lathe.

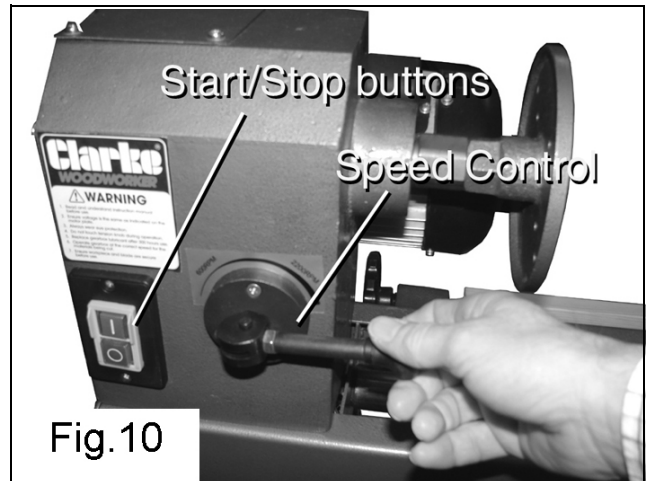

SPEED CONTROL

1. Set the speed using the speed control lever as shown in Fig 10. Always set the lever to the lowest setting before switching the machine on or off. The following settings serve as an approximate guide.

SPINDLE TURNING		
SQUARE	ROUGHING	FINISHING
1"	1700	2200
2"	1200	2200
3"	700	2200
4"	600	2200
FACE PLATE TURNING		
DIAMETER	ROUGHING	FINISHING
6"	1700	2200
8"	700	2200
9"	600	2200

COPY TURNING

1. Take the template object which is to be copied and mark diagonal lines on each end in order to show the centre point before installing it in the copy stock position. Pierce the template with the copy spindle spur (8) and then tighten both ends equally to hold the template as shown in Fig 11.

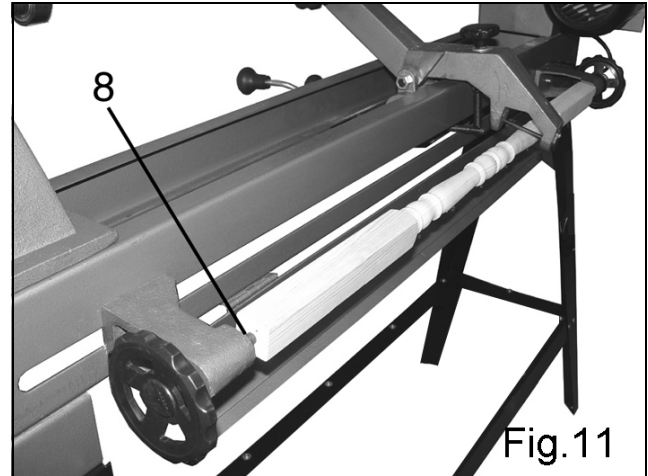

2. Set the new workpiece in the lathe by marking the centre point as above and securing in position between the head and tailstock as shown in Fig 12.



3. Begin turning by roughing off the workpiece until it is cylindrical and ready for fine turning.

4. Check that the copy follower is resting on the template object and will follow the outline profile as the assembly is moved along as shown in Fig 13.

5. Set the tool post such that the cutting tool is just level with the axis of the lathe and workpiece and begin turning progressively from one end, advancing the tool steadily. Take small cuts to assess the progress and check that the copy follower runs smoothly.

6. Progress slowly to ensure the copy follower roller/pin remains in contact with the template object at all times. Take care that the follower does not bounce on sudden shape changes. Different tools may be used according to the desired shape of the workpiece; e.g, round-nosed, square-nosed, spear point, etc. These may need changing during the operation.



MAINTENANCE

It is essential that the machine is properly maintained. Always inspect before use. Any damage should be repaired and faults rectified. The machine requires very little maintenance other than the following guidelines.

IMPORTANT: Disconnect from mains power before cleaning.

1. Vacuum clean any dust or shavings that accumulate in or on the motor.
 2. Check all cables periodically for security, and that they are in good condition and not cracked.
 3. Check tightness of mounting bolts.
 4. Check drive belt for wear and replace if frayed or otherwise damaged.
 5. Periodically lubricate the tail-stock, copy stock and tool carrier screw threads with engine oil such as SAE30 grade if they become stiff to use.
 6. Lightly lubricate the tail-stock and tool-post locking handles with oil if they become difficult to use.
- The ball bearings in the headstock and tail-stock spindles and in the copy live roller pin are greased and permanently sealed at the factory and require no further lubrication.

REPLACING THE BELT

1. Undo the retaining screws and remove the belt guard.
2. By pushing the speed control lever, expand the two halves of the driven pulley (27/29) allowing the belt to adopt its smallest diameter at this end.
3. Rotate the motor pulley (18/19) to dismount the drive belt from it and then lift it off the driven pulley.

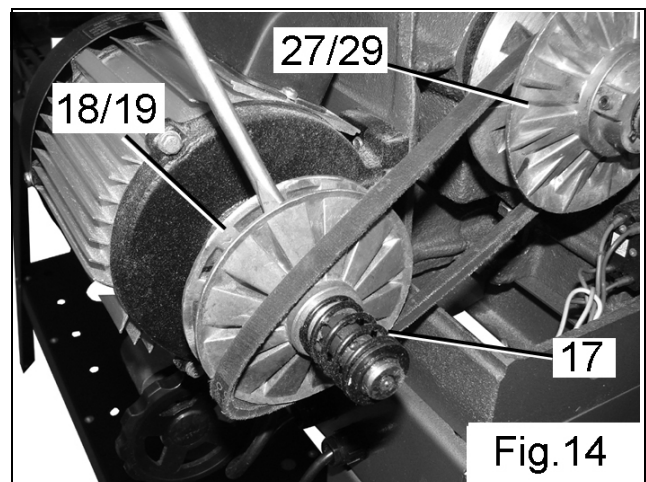

4. Replacement is a reverse of the removal procedure. A broad-bladed screwdriver or similar will be useful to prize the two halves of the motor pulley apart against the pressure of the spring (17). Ensure the left & right halves of the drive pulley spring back to grip the belt and that the belt is in tension.

In case of problems refer to TROUBLESHOOTING on page 17. If you are unable to rectify any faults, please contact your local dealer or Clarke International Service Department on 0208 988 7400 for assistance.

OPTIONAL ACCESSORIES

The following accessories are also available from your Clarke dealer:

Cup Turning Chuck	6500676
Screw Chuck	6500677
4-Jaw Independent Lathe Chuck	6500678
6" Faceplate (Right Hand)	6500679
8 Piece Chisel Set	6500649

TROUBLESHOOTING

Problem	Check	Solution
Motor will not run.	<ol style="list-style-type: none"> 1. Defective/broken switch. 2. Damaged power cable. 3. Open circuit, loose connections or burned out motor. 4. Blown fuse or circuit breaker 5. Low voltage 	<p>Replace or return to your Clarke dealer for repair.</p> <p>Replace cable or return to your Clarke dealer for repair.</p> <p>Return to your Clarke dealer for repair. Attempting to repair the motor may be hazardous unless carried out by a qualified technician.</p> <p>Replace fuse or re-set circuit breaker. Turn off other machines on the same circuit.</p> <p>Check the power supply for correct voltage. Use another circuit or have a qualified electrician upgrade the power supply.</p>
Motor will not start and fuses or circuit breaker trip out.	<ol style="list-style-type: none"> 1. Short circuit in motor or power cable. 2. Incorrect fuses or circuit breakers. 	<p>Return to your Clarke dealer for repair.</p> <p>Replace with correct fuse or circuit breaker for the circuit.</p>
Motor fails to reach full power.	<ol style="list-style-type: none"> 1. Overloaded circuit. 2. Unsuitable extension cable. 	<p>Turn off other machines & retry.</p> <p>Replace with correct size extension cable (rated at <math><0.75\text{mm}^2</math> section).</p>
Motor stalls.	<ol style="list-style-type: none"> 1. Short circuit in motor. 2. Incorrect fuses or circuit breakers. 3. Overloaded circuit. 4. Low voltage. 	<p>Return to your Clarke dealer for repair. Attempting to repair the motor may be hazardous unless carried out by a qualified technician.</p> <p>Replace with correct fuse or circuit breaker for the circuit.</p> <p>Turn off other machines & retry.</p> <p>Check the power supply for correct voltage. Use another circuit or have an electrician upgrade the service.</p>
Noisy operation	<ol style="list-style-type: none"> 1. Incorrect belt tension. 2. Worn bearings. 	<p>Adjust belt tension. See "Replacing the Belt" section on page 15.</p> <p>Overhaul or return to your Clarke dealer for repair</p>
Tailstock loose on bed	Locking handle not tight.	Tighten locking handle
Wood burns at tailstock end	Tailstock set too tight. Lack of lubrication.	Ease off tailstock adjustment and lubricate tailstock spur.

PARTS DIAGRAM

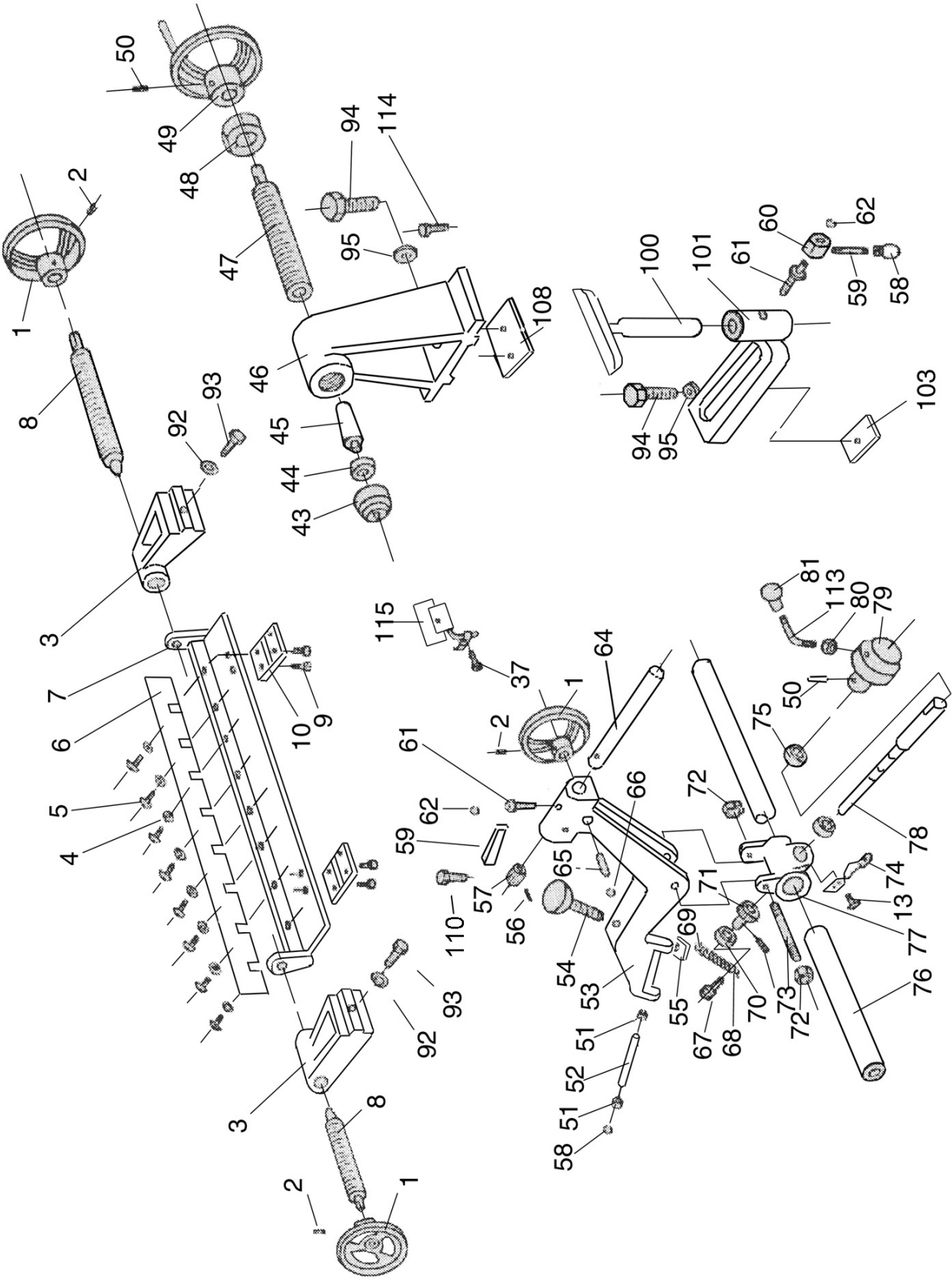

PARTS LIST

PART NO	DESCRIPTION	PART NO	DESCRIPTION
1	Hand wheel	32	Speed positioning lever
2	Grub screw M6 x 10	33	Coil spring
3	Support arm	34	Nut M8
4	Washer 8mm	35	Bolt M8 x 25mm
5	Machine screw M6x 8	36	Speed control shaft
6	Folded plate	37	Socket head bolt M8 x 20
7	Movable plate	38	Circlip
8	Copy spindle	39	Bearing 80205
9	Bolt M6 x 8	40	Circlip 52 dia
10	Hinge	41	Spindle key
11	Self tapping screw M4 x 8	42	Headstock spindle
12	Spindle cover plate	43	Tailstock spur
13	Grub screw M5x8	44	Bearing 80201
14	Power cable	45	Taper shank
15	Circlip 22mm	46	Tailstock body
16	Penny washer	47	Tailstock spindle
17	Coil spring	48	Lock nut M18
18	Motor pulley (left)	49	Tailstock handwheel
19	Motor pulley (right)	50	Grubscrew M8 x 8
20	Washer 5mm	51	Bearing 80025
21	Parallel key	52	Living roller arm pin
22	Motor	53	Copy follower body
23	Headstock body	54	Copy tension screw
24	Faceplate	55	Spring attachment plate
25	Spur centre	56	Grubscrew M6 x 5mm
26	Circlip 24 dia	57	Tool carrier pinion
27	Driven Pulley (right)	58	Cover tab
28	Drive belt 560mm circ	59	Locking handle arm
29	Driven Pulley (left)	60	Wear block
30	Circlip 55 dia	61	Screwed shank
31	Bearing BO106	62	Screw

PARTS DIAGRAM

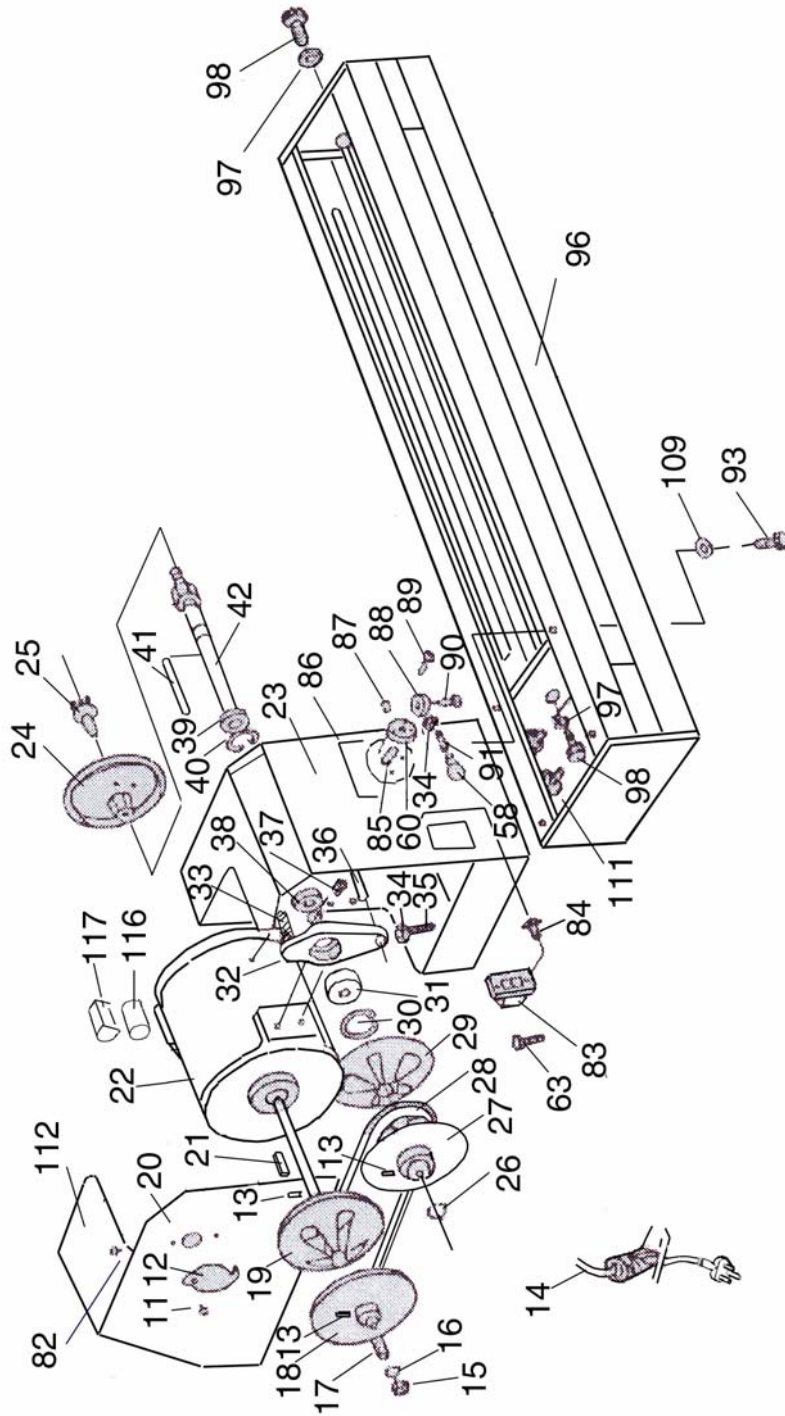

PARTS LIST

PART NO	DESCRIPTION	PART NO	DESCRIPTION
63	Bolt M6x25	94	Bolt M16 x 35
64	Copy toolholder rack	95	Washer 16mm
65	Copy toolholder pinion	96	Lathe bed
66	Circlip 8mm	97	Washer 10mm
67	Slot headed bolt	98	Bolt M10 x 18
68	Copy tension spring	99	Stand top plate
69	Circlip 6mm	100	Chisel rest
70	Bearing 80200	101	Chisel rest holder
71	Leadscrew pinion	102	Stand front (right)
72	Nut M12	103	Tool holder anchor plate
73	Copy pivot stud	104	Stand long support
74	Leadscrew bearing rest	105	Stand front (right)
75	Bearing 80201	106	Stand cross support
76	Leadscrew guide rack	107	Coachbolt M8 x 12
77	3-way trunnion	108	Securing plate
78	Leadscrew axle	109	Washer 8mm
79	Leadscrew hub	110	Tool retaining bolt
80	Nut M10	111	Cable gland
81	Knob	112	Belt guard
82	Cover retaining screw	113	Leadscrew handle
83	On/Off switch	114	Bolt M8 x16
84	Screw M12 x 12	115	Eye shield
85	Speed control spindle	116	Capacitor 10uF
86	Speed label	117	Capacitor cover
87	Circlip		Open spanner
88	Speed control cam		Drift rod
89	C/sunk screw M4x20		Hex key S3
90	Pin		Hex key S4
91	Speed control lever		T-wrench
92	Washer M8		
93	Bolt M8x20		

PARTS DIAGRAM-BASE FRAME

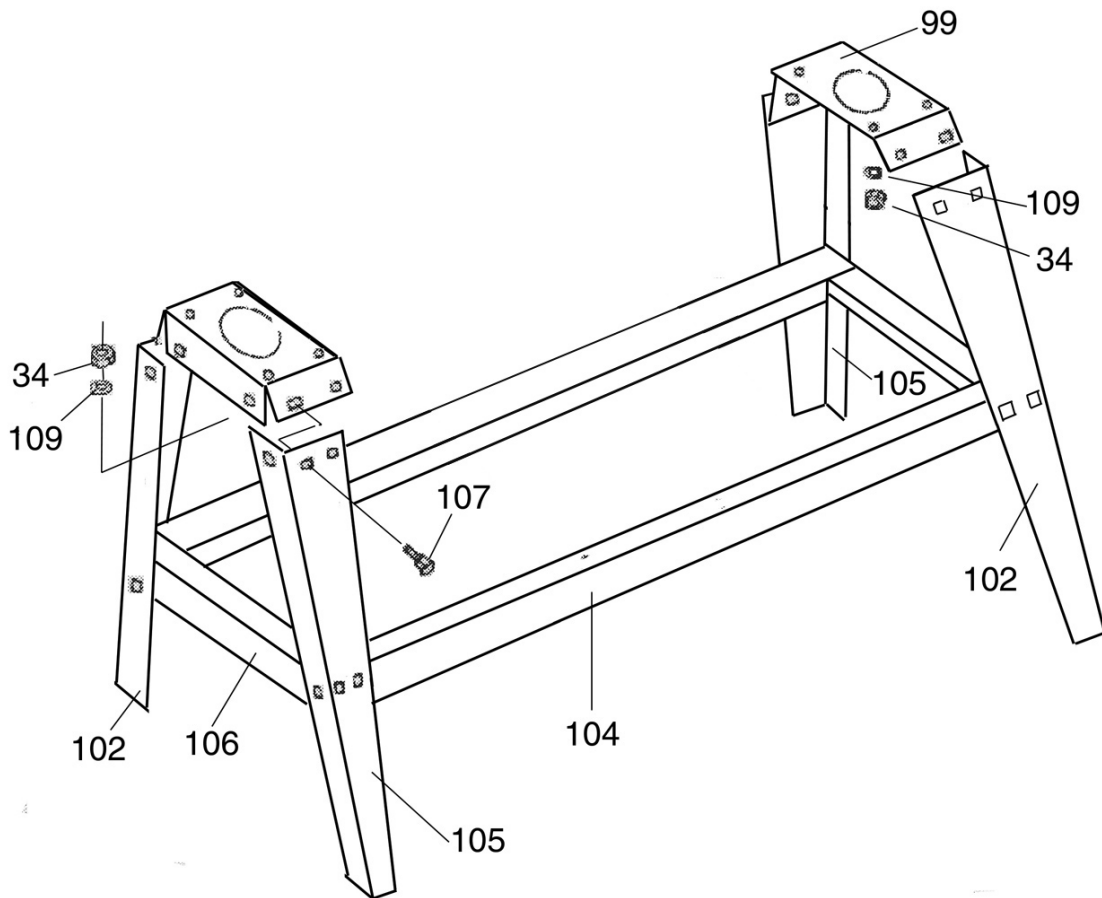

GUARANTEE

This CLARKE product is guaranteed against faulty manufacture for a period of 12 months from the date of purchase. Please keep your receipt as proof of purchase.

This guarantee is invalid if the product is found to have been abused or tampered with in any way, or not used for the purpose for which it was intended.

Faulty goods should be returned to their place of purchase, no product can be returned to us without prior permission.

This guarantee does not effect your statutory rights.

DECLARATION OF CONFORMITY

UK CA

CLARKE
INTERNATIONAL

Hennell Street, Epping, Essex, CM16 4LG

DECLARATION OF CONFORMITY

This is an important document and should be retained.

We hereby declare that this product(s) complies with the following legislation:

Electromagnetic Compatibility Regulations 2016
Supply of Machinery (Safety) Regulations 2008
The Restriction of the Use of Certain Hazardous Substances in Electrical and Electronic Equipment Regulations 2012

The following standards have been applied to the product(s):

EN IEC 55014-1:2021, EN IEC 55014-2:2021, EN 61000-3-2:2019+A1:2021,
EN 61000-3-3:2013+A1:2019+A2:2021, EN 62841-1:2015+A1C:2015,
IEC 62841-1:2014+C1:2014+C2:2015.

The technical documentation required to demonstrate that the product(s) meet(s) the requirement(s) of the aforementioned legislation has been compiled and is available for inspection by the relevant enforcement authorities.

The UKCA mark was first applied in: 2023

Product Description: 40" 1000mm Wood Turning Lathe with Variable Speed & Copy Follower
Model Number(s): CWL1000CF
Serial/Batch Number: Refer to product/packaging label
Date of Issue: 26/01/2023

Signed: 
J.A. Clarke
Director

CWL1000CF UKCA Clarke DOC 012623 Page 1 of 1

CE

CLARKE
INTERNATIONAL

Fitzwilliam Hill, Fitzwilliam Place, Dublin 2

DECLARATION OF CONFORMITY

This is an important document and should be retained.

We hereby declare that this product(s) complies with the following legislation:

2014/30/EU *Electromagnetic Compatibility Directive*
2006/42/EC *Machinery Directive*
2011/65/EU *Restriction of the Use of Certain Hazardous Substances in Electrical & Electronic Equipment (RoHS) Directive*

The following standards have been applied to the product(s):

EN IEC 55014-1:2021, EN IEC 55014-2:2021, EN 61000-3-2:2019+A1:2021,
EN 61000-3-3:2013+A1:2019+A2:2021, EN 62841-1:2015+A1C:2015,
IEC 62841-1:2014+C1:2014+C2:2015.

The technical documentation required to demonstrate that the product(s) meet(s) the requirement(s) of the aforementioned legislation has been compiled and is available for inspection by the relevant enforcement authorities.

The CE mark was first applied in: 2018

Product Description: 40" 1000mm Wood Turning Lathe with Variable Speed & Copy Follower
Model Number(s): CWL1000CF
Serial/Batch Number: Refer to product/packaging label
Date of Issue: 26/01/2023

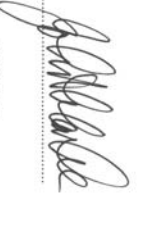
Signed: 
J.A. Clarke
Director

CWL1000CF CE Clarke DOC 012623 Page 1 of 1

A SELECTION FROM THE VAST RANGE OF

Clarke®

QUALITY PRODUCTS



AIR COMPRESSORS
From DIY to industrial, Plus air tools, spray guns and accessories.

GENERATORS
Prime duty or emergency standby for business, home and leisure.

POWER WASHERS
Hot and cold, electric and engine driven - we have what you need

WELDERS
Mig, Arc, Tig and Spot. From DIY to auto/industrial.

METALWORKING
Drills, grinders and saws for DIY and professional use.

WOODWORKING
Saws, sanders, lathes, mortisers and dust extraction.

HYDRAULICS
Cranes, body repair kits, transmission jacks for all types of workshop use.

WATER PUMPS
Submersible, electric and engine driven for DIY, agriculture and industry.

POWERTOOLS
Angle grinders, cordless drill sets, saws and sanders.

STARTERS/CHARGERS
All sizes for car and commercial use.



PARTS & SERVICE: 0208 988 7400

Parts Enquiries
Parts@clarkeinternational.com

Servicing & Technical Enquiries
Service@clarkeinternational.com

SALES: UK 01992 565333 or Export 00 44 (0)1992 565335

Clarke INTERNATIONAL Hemnall Street, Epping, Essex CM16 4LG
www.clarkeinternational.com